

imagine

**BI-FOLD DOOR
INSTALLATION MANUAL
NOVEMBER 2019**

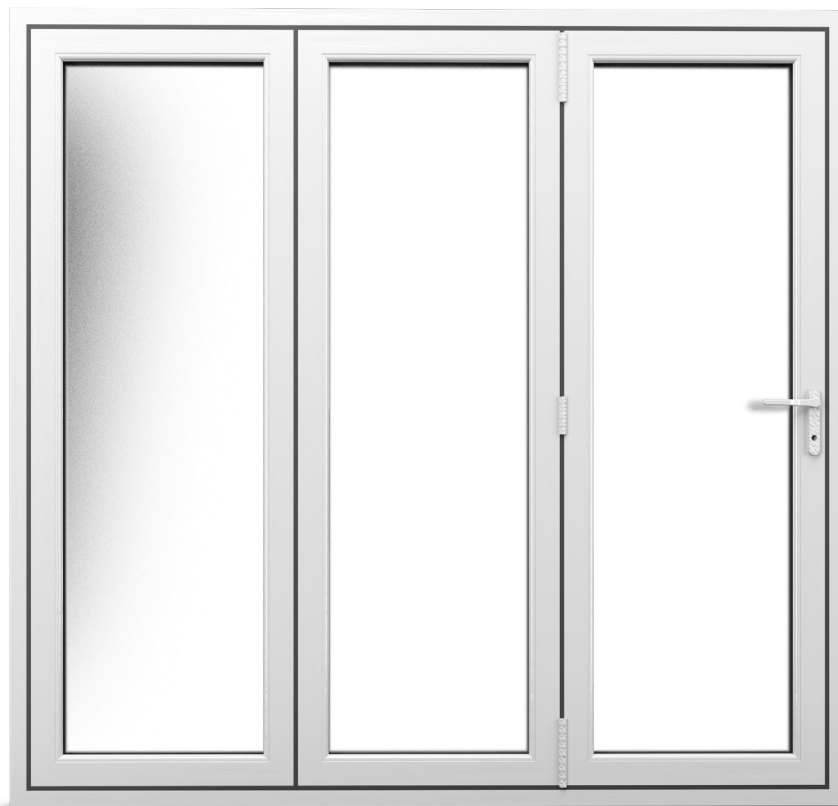

NOTES

A series of 20 horizontal dotted lines for taking notes.



GUIDELINES

Guidelines, Advice & General Information

Bi-Fold doors are a specialist product and thought needs to be given in regards to manufacture and installation. Tolerances are critical, therefore VEKA Plc recommends this product is manufactured on its own line or a specials line and should not be treated as a mainline product.

Although it is possible to manufacture a six metre, seven pane Bi-Fold door, when dark foiled profiles are installed in south facing locations or where the possibility of internal or external heat build-up could be a factor, it is recommended to limit the number of sashes to four. In all cases, sufficient expansion allowance and adequate ventilation should be included. Please refer to the latest VEKA Variations document for guidance on light and dark coloured foils.

All frames and sashes must be fully reinforced regardless of colour size.

Due to the nature of Bi-Fold doors and their assembly, they should be classed as domestic products only and the location in which they are to be installed should be clarified in advance.

A lintel or structural reinforcement may be required over large spans. Suitable strength must be available to ensure solid fixing at the correct centres along the head of the frame, a structural engineer may need to be consulted to ensure this. It is recommended to use a portal frame in conservatories, please consult the roof supplier for advice on this.

It is not possible to use thumbturn cylinders as they will clash with the opposite sash when closing, causing damage. Leaving keys in the cylinder when folding the doors will also cause damage. Alternative doors handles may be fitted but will clash if they project more than 22mm from the sash jamb. Using third party products will result in the product being void from the ERA five star guarantee and will also not be covered for PAS 24 without further testing.

It is possible to have all key locking sashes to operate using one key. Examples of this would be where you have 2 master handles on a door style such as a 4:3:1 or if the additional security measure of an auxiliary lock with cylinder is fitted on sashes with our low level, contemporary espag handle (eg. 3:3:0). For a Keyed Alike cylinder option please contact the ERA sales team directly on 01922 490 049, quoting the VEKA Plc Imagine Bi-Fold Door. Please be aware that all PAS 24 enhanced security testing was achieved using ERA cylinders, and therefore must be used in compliance with the test reports. In addition, the use of ERA cylinders is a prerequisite of the ERA 5-Star Guarantee Scheme.

The profiles and system used within this manual are designed to be internally beaded only.

The information provided in this manual should be treated as guidance only. VEKA Plc cannot control how the information is interpreted and therefore cannot be held responsible for any failure. Regulations regarding the health and safety of operatives along with relevant building regulations should be strictly adhered to. VEKA Plc therefore cannot be held responsible for any failure to comply with them. This statement does not affect the fabricators statutory rights.

Do not scale from drawings in this manual. The drawings shown are visual representations only. VEKA Plc has the right to alter the designs, specification and descriptions without prior notice as part of our policy of continuous development and improvement.

Bi-Fold doors manufactured in accordance with this manual are covered by the ERA 5-Star Guarantee, terms and conditions apply. For more details contact the VEKA Plc sales team.



CONTENTS

COMPONENTS	1
SURVEY	2
INSTALLATION	3
GLAZING	4
AMENDMENTS	5



CONTENTS

6	PROFILE COMBINATIONS
7	SURVEY
8	PRE-INSTALLATION CHECKS
9	ASSEMBLING MECHANICAL JOINTED FRAMES
10	LOW THRESHOLDS
11	INSTALLATION OF THE NEW FRAME
12	THRESHOLD RAMPS
13	INSTALLING OF THE NEW FRAME
14	FIXING & PACKERS
15	ASSEMBLING MECHANICALLY JOINTED FRAMES
16	CONNECTING THE SASH TO THE FRAME
17	CONNECTING SASH TO SASH
18	SASH HINGES
19	OUTER FRAME THERMAL INSERT
20	MAGNETS
21	GLAZING
22	GLAZING PACKERS
23	FINAL CHECKS
24	TRIMMING & SEALING
25	ADJUSTMENT
26	HORIZONTAL ADJUSTMENT CONTINUED
27	COMPONENTS
28	COMPONENTS – CONTINUED
29	DOOR RESTRICTOR
30	DOOR RESTRICTOR – CONTINUED
31	OPTIONAL SPARES & MAINTENANCE
32	AMENDMENTS 1
33	AMENDMENTS 2



PROFILE COMBINATIONS

1

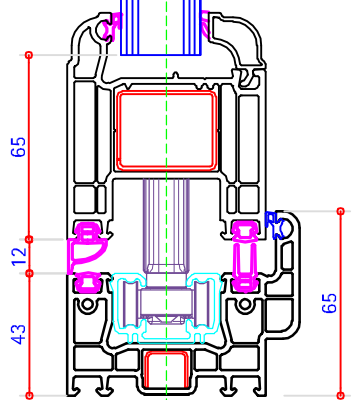
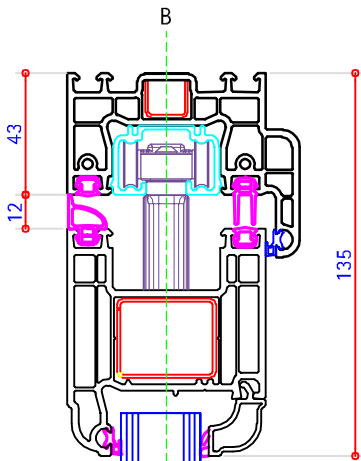
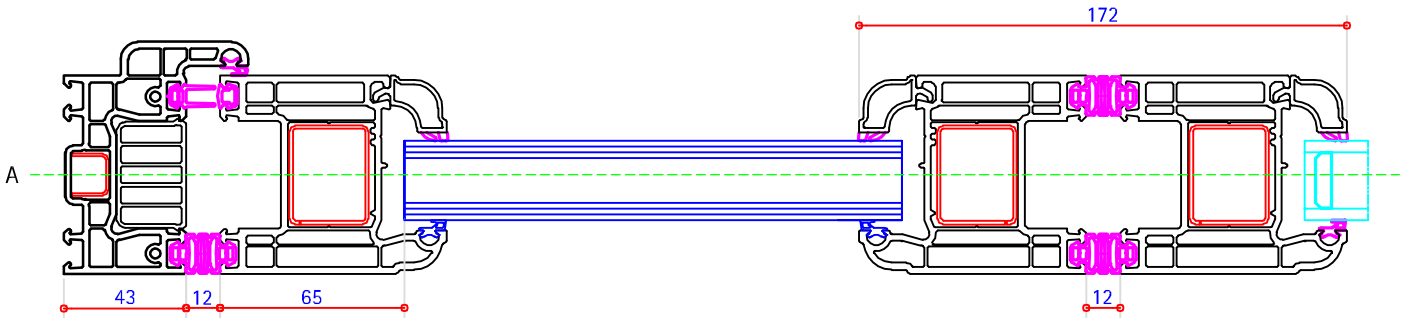
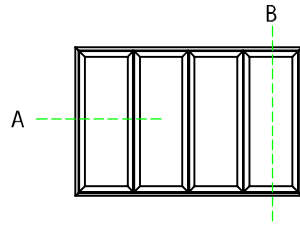

65mm Outer Frame 105174
80mm Sculptured Sash 105175

Alternative Threshold Options

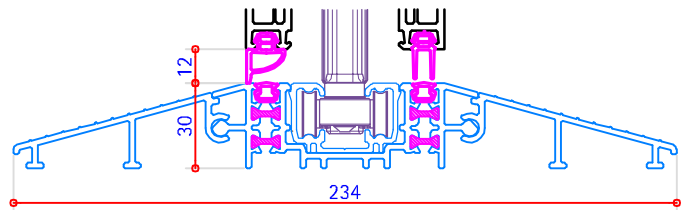

Low Threshold 104392
(2x) Threshold Ramp 104391
80mm Feature Sash 105175

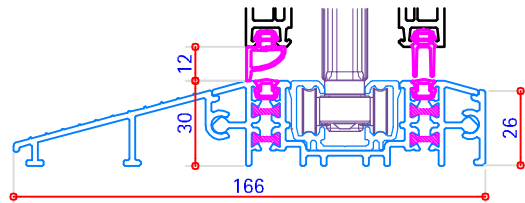

Low Threshold 104392
(1x) Threshold Ramp 104391
(1x) Threshold Blank 104394
80mm Feature Sash 105175

⚠ NB: For internal use only.

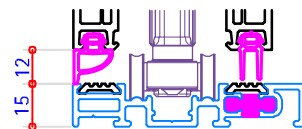

Room Divider Threshold 104390
80mm Feature Sash 105175

Dimensions also apply to bevelled sash.



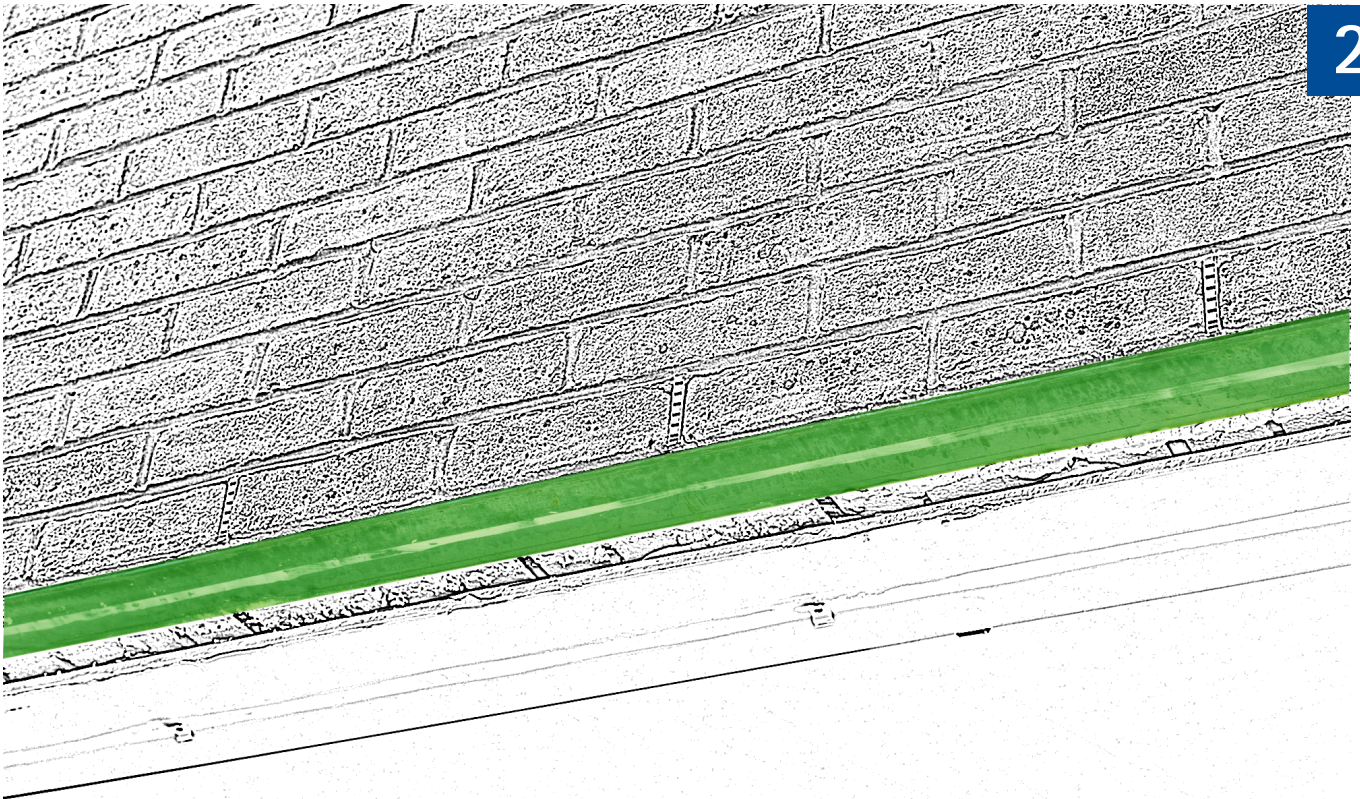

Survey

The following document should be treated as a guide only, the installation should comply with all elements of BS8213-4 code of practice for the survey and installation of windows and external door sets. Please also observe all relevant health and safety regulations.

Good surveying is the basis of ensuring a quality installation. The opening should provide a solid structure for the frame to be fixed into. PVC Frames are not designed to be structural, no load should be transferred to the frame, and therefore it is essential that sufficient support is provided above the frame by use of a lintel or portal frame, a structural engineer or conservatory roof supplier may need to be consulted for advice on this. A portal frame would be recommended when installing a Bi Fold into a conservatory or where all 4 sides cannot be fixed direct into the building.

Sufficient expansion allowance should be taken into account, refer to this table for recommended deductions.

	1.5m to 3.0m	3.0m to 4.5m	4.5m +
White PVC	10mm	15mm	20mm
Dark Coloured PVC	15mm	22mm	28mm



PRE-INSTALLATION CHECKS

Before removal of the existing frame can commence check the specification of the new frame and glass is correct.

- Measure the existing opening and check the size of new frame to ensure it is correct.
- Check the size of the glazing units to ensure these are the correct size for the frame.
- Check all ancillary items and fittings such as cills or handles are available. If a cill is required check the concealed drainage is present, if no cill has been specified face drain slots and caps will be required.
- Remove any furniture that may cause an obstruction or could be damaged during installation.
- Cover any furniture or flooring that cannot be moved with protective sheets.

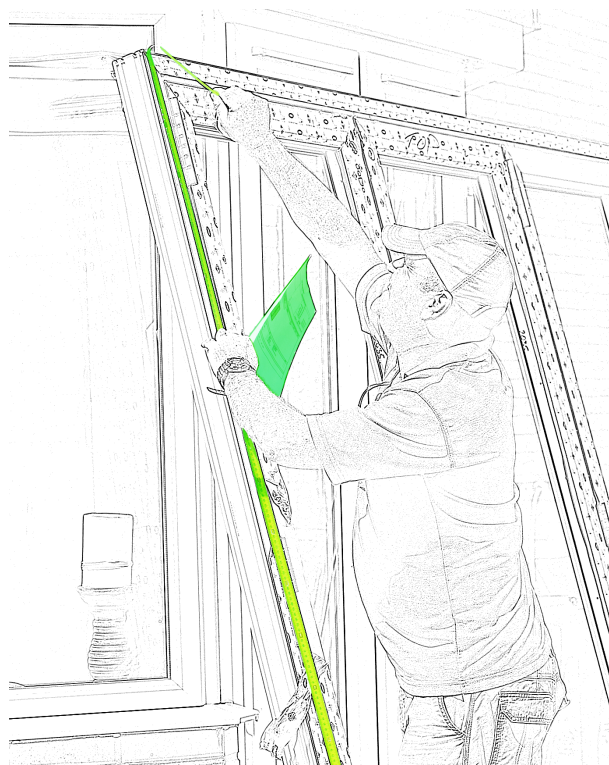

Removal Of The Old Frame

Carefully remove the old frame taking care to avoid any unnecessary damage to the building structure and its finishing's. Ensure the area is clear of debris and loose brickwork, render or plaster is repaired.



ASSEMBLING MECHANICAL JOINTED FRAMES

Frame Corners

3

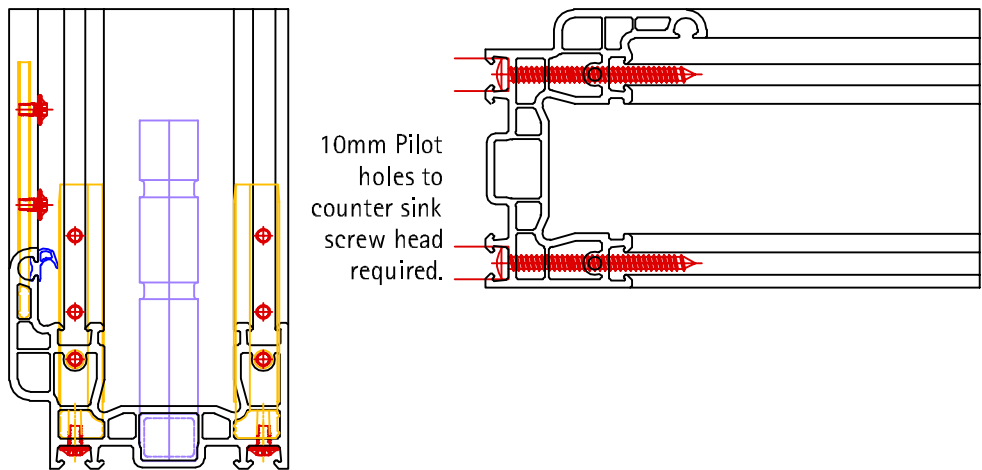
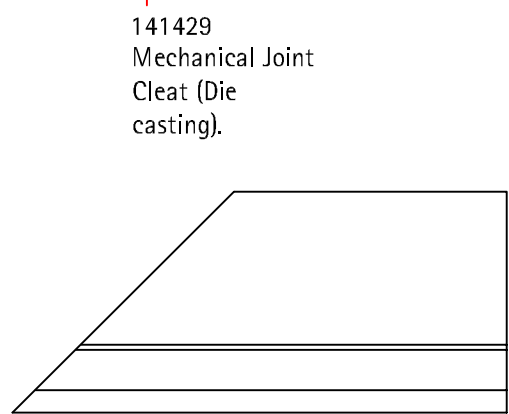
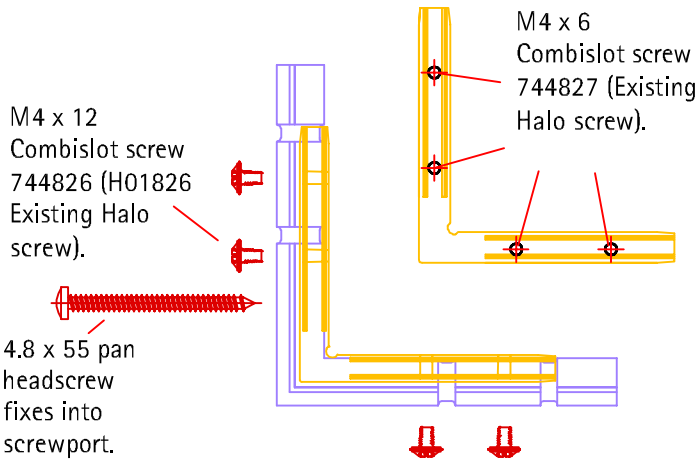
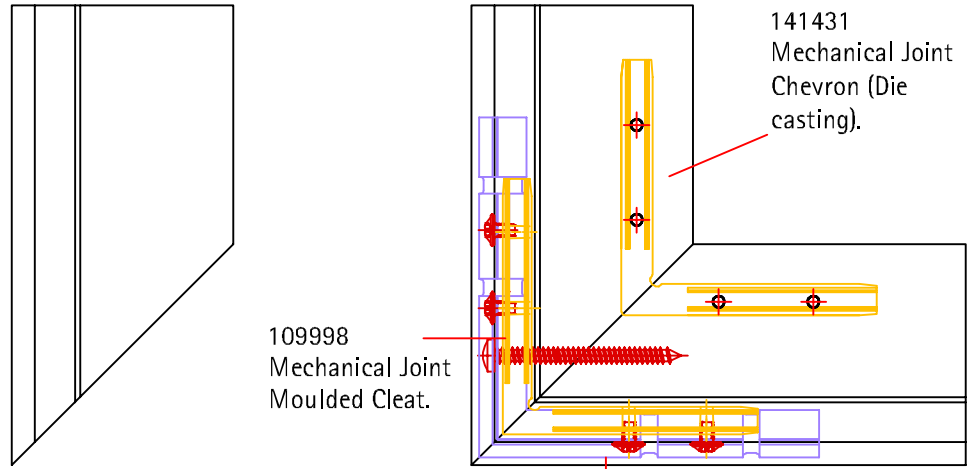

LOW THRESHOLDS

Low Threshold 104392

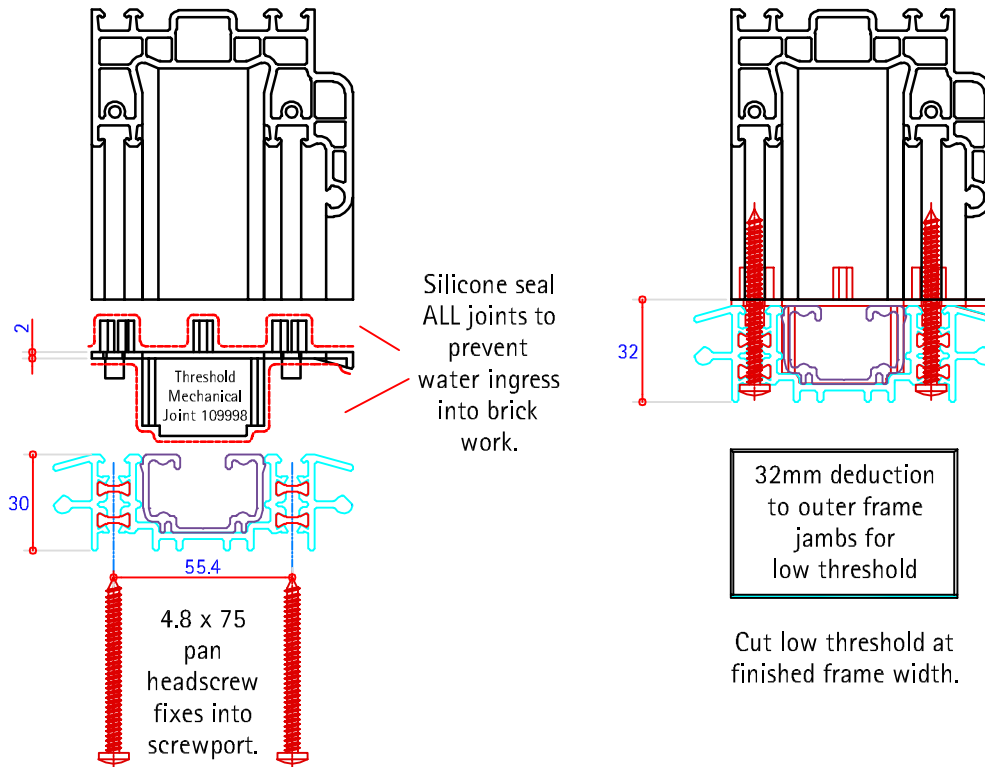

3

Room Divider Threshold 104390

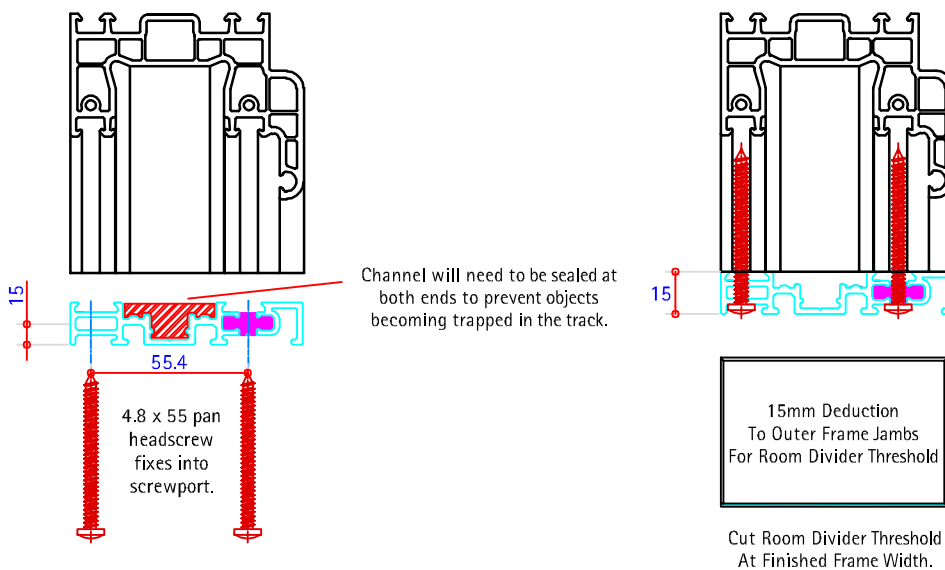

INSTALLATION OF THE NEW FRAME

Install the cill if one is required. Great care should be taken to ensure the cill or bottom rail of the frame is fully supported along the total length and is completely level without any evidence of twist or distortion. Due to the width of most Bi folding doors being above 2m a laser level or similar would be advantageous to check this. Where an aluminium threshold has been used the threshold ramps or blanks must be fitted prior to securing the bottom rail. Any fixings through the cill or bottom rail must be sealed to prevent water seepage. Suitable fixings should be used to secure the frame.

3

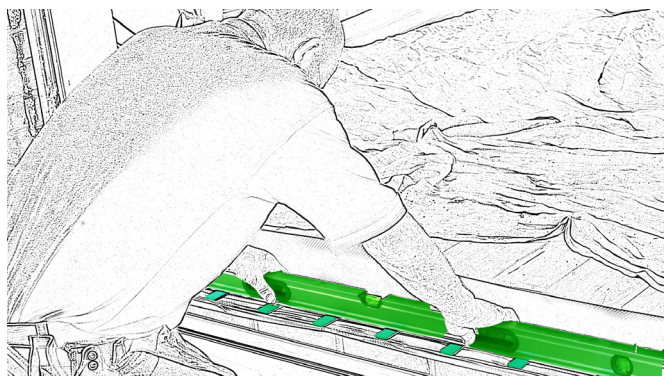

Aluminium Threshold.

OPTIONAL 104391 (Threshold ramp required to comply with document M).

OPTIONAL 104394 (Threshold blank).

The threshold ramp 104391 & threshold blank may not be fitted to prevent damage during transportation and must be fitted before installation unless sufficient access is available.

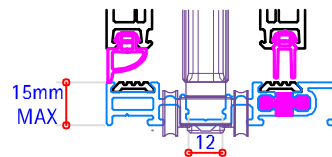
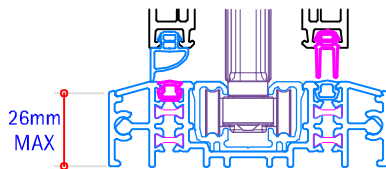
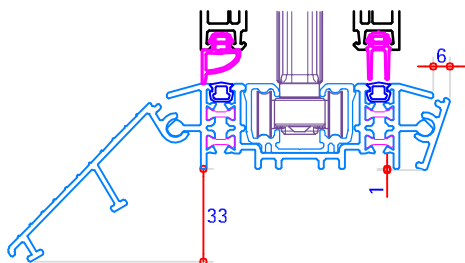

Burying the low document M & room divider thresholds (not suitable for weather applications).



THRESHOLD RAMPS

The threshold ramps can be held in position during installation by inserting a 38mm packer as illustrated. A soft foam or styrofoam packer is recommended. Take care to avoid any drainage holes if the packer can not be removed after installation.

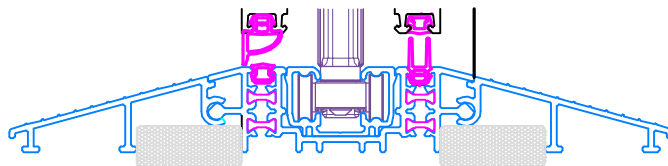

3

There are two principal methods of fixing available, which may be used separately or in combination. These are through frame fixings and lug fixings. The manufacturer's instructions should always be followed. If lug fixings are used they should be of a suitable material to resist corrosion and, if used externally, they should be secured to the wall using "one-way" or other suitable security screws.

Screws should be sized to penetrate at least 25mm into timber, or 40mm into plugged holes in brick, block, or masonry, unless equivalent demonstrable provision can be made by other means, for example by complying with an appropriate structural code. Connections to steelwork up to 2mm thick such as folded sheet lintels should be made with appropriate thread cutting screws. Connections to steelwork over 2mm thick should be into pre-tapped holes with machine screws of minimum 5mm diameter or alternatively with power-driven hardened self drilling screws.

Other proprietary mechanical fixing methods should be assessed for suitability, preferably by obtaining an appropriate third party assessment. Fixings should be at least as corrosion-resistant as BS EN 1670:1998, Grade 3. The presence of pre-cast concrete or steel lintels may make it impracticable or pose severe difficulties in achieving the specified fixing distances. In these instances the use of polyurethane foam has proved a useful adjunct to mechanical fixings. However, foam fixings should never be used as the sole method of fixing the entire frame into the reveal.

Rap Anchor - Recommended fixing with low threshold and room divider threshold to prevent fouling the rollers.

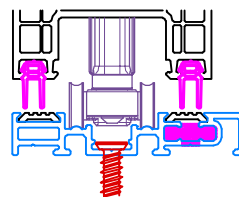
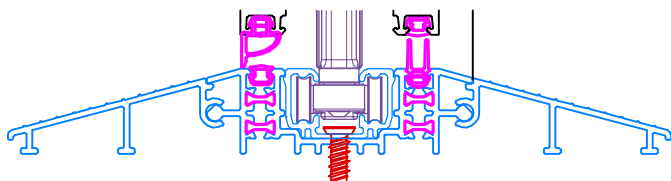

INSTALLING OF THE NEW FRAME

All four sides of the frame should be secured as follows:-

- Corner fixings should be between 150 mm and 250 mm from the external corner.
- Intermediate fixings should be at centres no greater than 600mm

3

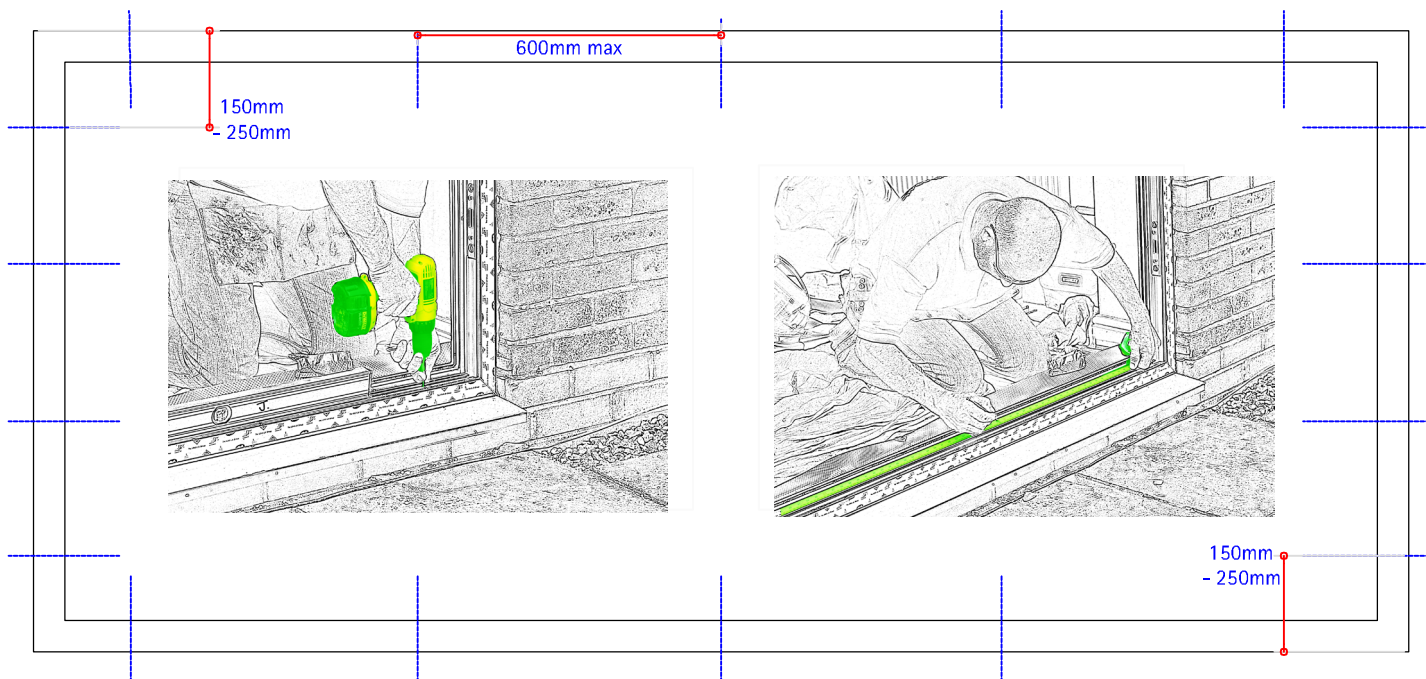

It is imperative the head of the frame is fixed parallel with the bottom rail again ensuring the frame is free from distortion or twist. This can be checked by use of a level along with a length of timber or similar cut to the size of the rebate positioned at fixing points along the frame.



FIXING & PACKERS

Where a fixing is required on a jamb fitted with a keep, fixings should be placed through the allen key adjustment bolts & behind the removable plastic covers.

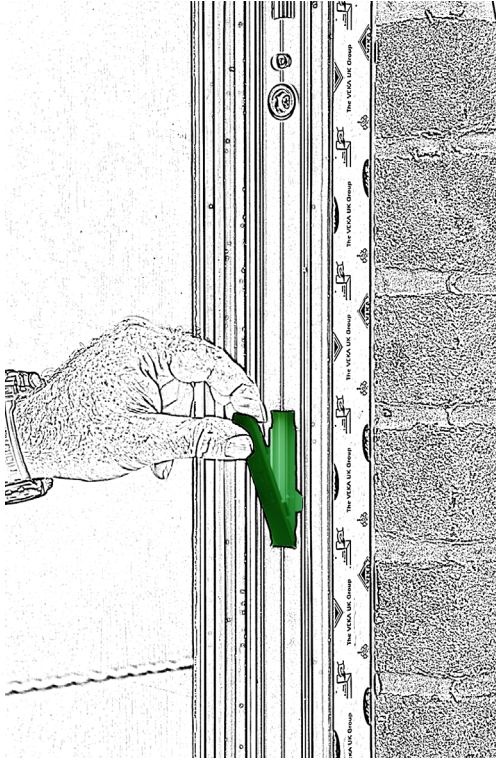

Adequate support by use of glazing packers or similar should be positioned between the frame and brickwork to prevent any twist or distortion of the frame when tightening the fixings.

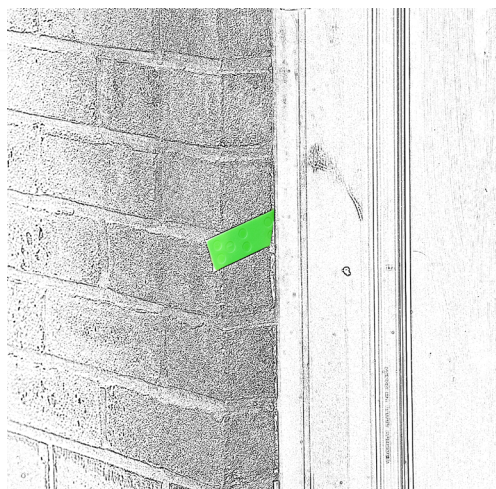

ASSEMBLING MECHANICALLY JOINTED FRAMES

Track 104393

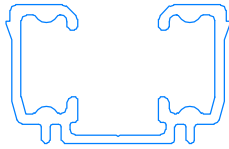

In order to attach the sashes to frame it is necessary to fit the top and bottom track in two pieces.

3

1. Measure the rebate of the frame.



2. Cut two lengths of 107393 track.

3. Select an appropriate point on the track to make a cut. This must be greater than 400mm to allow the roller to be easily loaded into the track avoiding any point which will affect the smooth operation of the rollers.

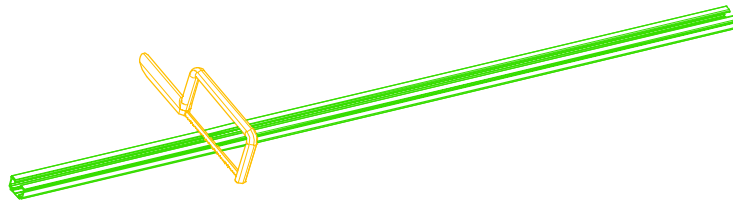

4. Attach the larger section of track to the frame using 3.9mm x 10mm screws. Seal the screws with silicone. Ensure screws used do not hinder the rollers. Repeat at top.

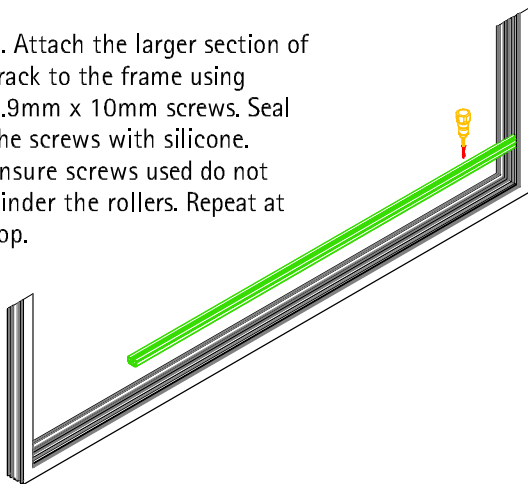

5. Once the sashes and rollers have been loaded onto into the frame attach the remaining section of the track. Repeat at top.

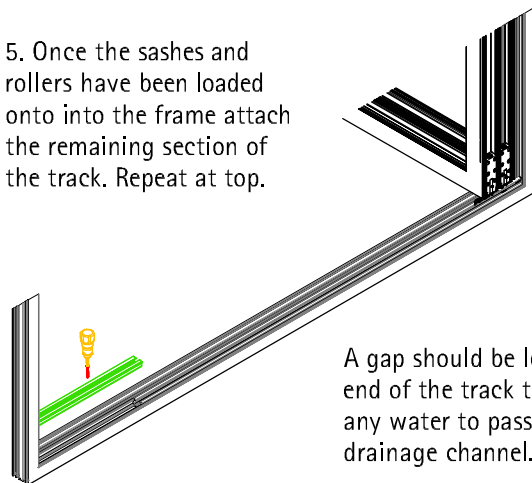

A gap should be left either end of the track to allow any water to pass into the drainage channel.

Suggested positions for breaks in tracks.

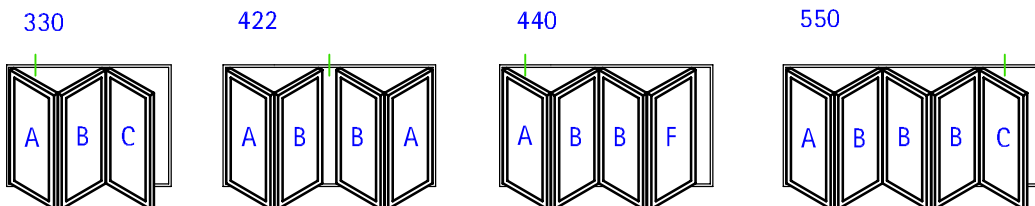

CONNECTING THE SASH TO THE FRAME

Extended Butt Hinge 17655 (01 = white, 10 = black)
Standard Butt Hinge 17651 (01 = white, 10 = black)

3

Hinges are factory set for a 12mm gap between the rebate of the frame and the edge of the sash.

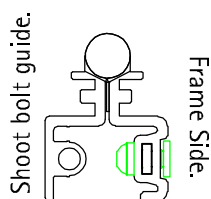

FITTING HINGE FOR SASH TO FRAME

1. Snap on the frame packer supplied to all hinges that re attached to the frame. This packer is not required for sash to sash hinges.

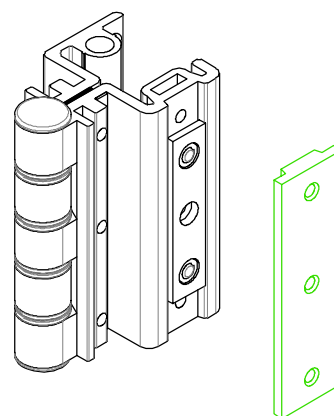

2. Attach the first sash by fixing the screws through the pre-drilled holes or by using the short hinge guide against the frame rebate to set the height attach hinges to the frame using 3 x 3.9 x 32mm steel screws & 3 x 3.9 x 45mm PVC Screws. Ensure the packers are on the part of the hinge attached to the frame.

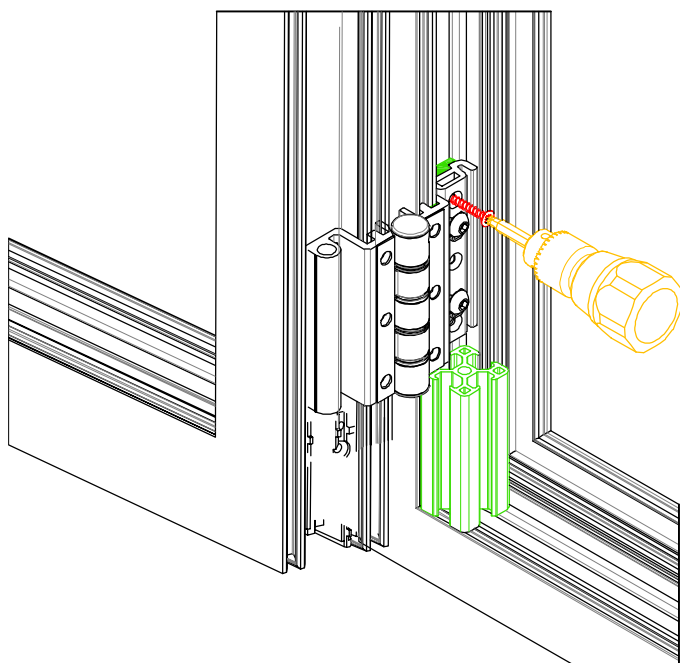

3. Attach the centre and top hinges to the frame using 3 x 3.9 x 32mm steel screws & 3 x 3.9 x 45mm PVC Screws in each hinge.

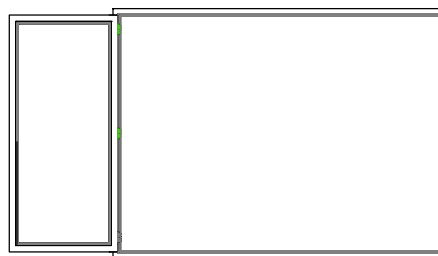

CONNECTING SASH TO SASH

Assembling Mechanical Jointed Frames

Connect the each adjacent pair of sashes using the hinges with 3 x 3.9 x 32mm steel screws & 3 x 3.9 x 45mm PVC screws to each hinge.

3



Connect the remaining sash to either the frame or adjacent sash were required.

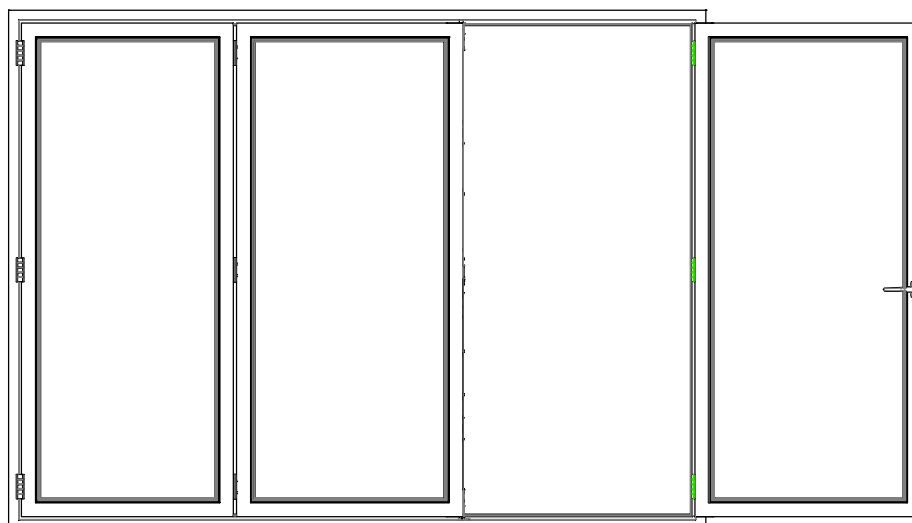

SASH HINGES

For sash to sash hinges are factory set to allow a 12mm gap when closed.

3

Attach hinges to sash using 3 x 3.9 x 25mm steel screws & 3 x 3.9 x 45mm PVC screws.

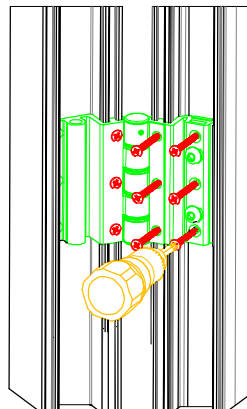

Attach hinges to sash using 3 x 3.9 x 25mm steel screws & 3 x 3.9 x 45mm PVC Screws.

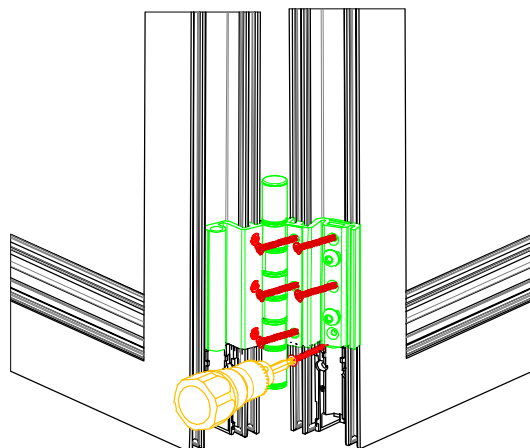

Repeat at top.



OUTER FRAME THERMAL INSERT

Assembling Mechanically Jointed Frames

105177 Outer Frame Thermal Insert 105177.100101 - White
105177.180201 - Brown
105177.180701 - Caramel

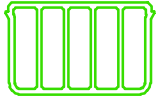

3

Use the outer frame thermal insert to fill the channel between the hinges.

1. X = Measure the distance between hinges on the outer frame.
2. Cut the 105177 to this size.
3. Firmly snap into place between the hinges.

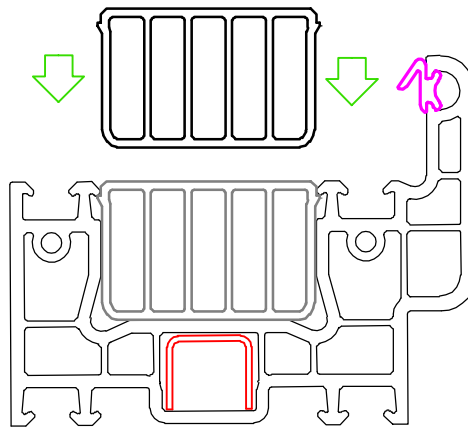
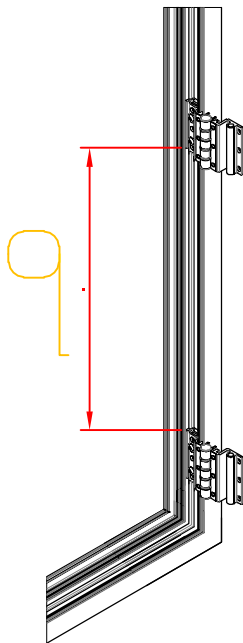

OPTIONAL Snap on Plastic Hinge Covers 17693_{xx} (01 = White, 10 = Black).

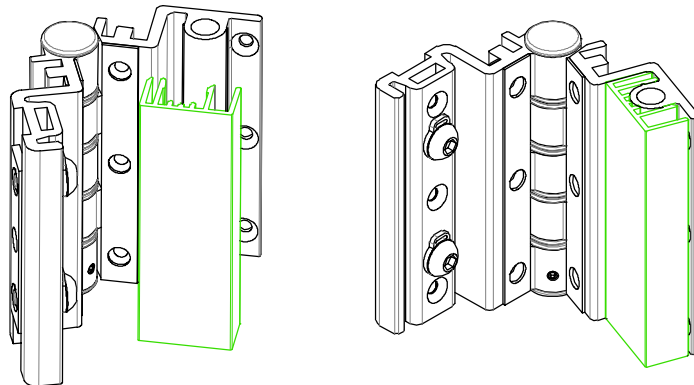
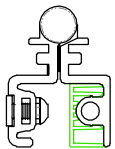

MAGNETS

OPTIONAL Magnets 18031_{xx} (01 = White, 10 = Black, 34 = Chrome, 35 = Gold).

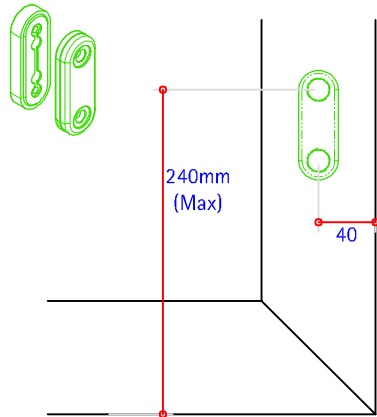

Suggested positions for magnets .

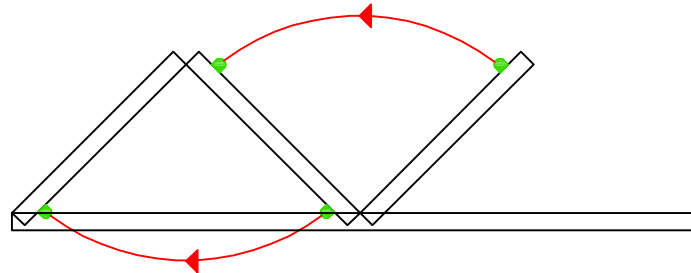

Magnets may be fitted either at the top or bottom of the sash. The magnets are designed to retain the sashes in the open position in normal weather conditions.

3

Standard assembly when 17998 rose handle is used.

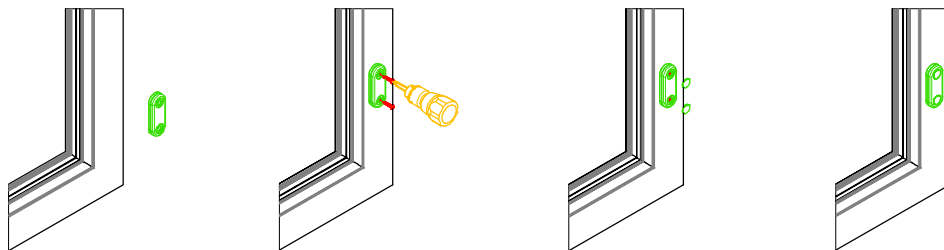

1. Attach using 2 x 3.9 x 32mm steel screws.

2. Conceal the fixings using snap on covers provided.

Assembly option when a larger handle is used using packer provided.

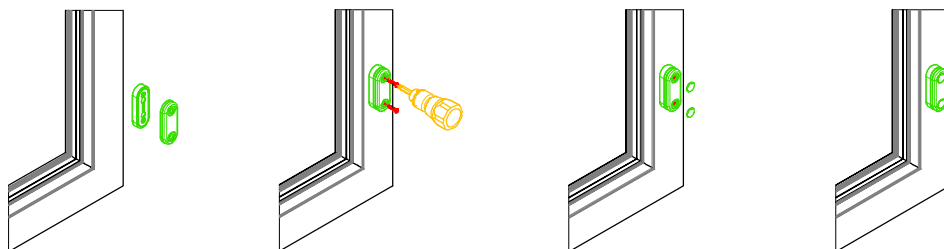

1. Attach using 2 x 3.9 x 45mm steel screws.

2. Conceal the fixings using snap on covers provided.



GLAZING

All glass should be in accordance with BS6262. Prior to installing any glass unit or panel, the Clip In Packer 109377 must be fitted into the glazing rebates of the sashes wherever the glazing unit has to be packed or spaced.

The Clip In Packer:

- Raises the unit above the rebate and level to the bead groove.
- Acts as a Bridge Block when used in the bottom rails to allow drainage of the rebate.
- Provides a flat surface from which to pack or space the glass.
- Prevents the glazing unit standing in water, helping to prolong the integrity of the seals to the glazing unit.

4

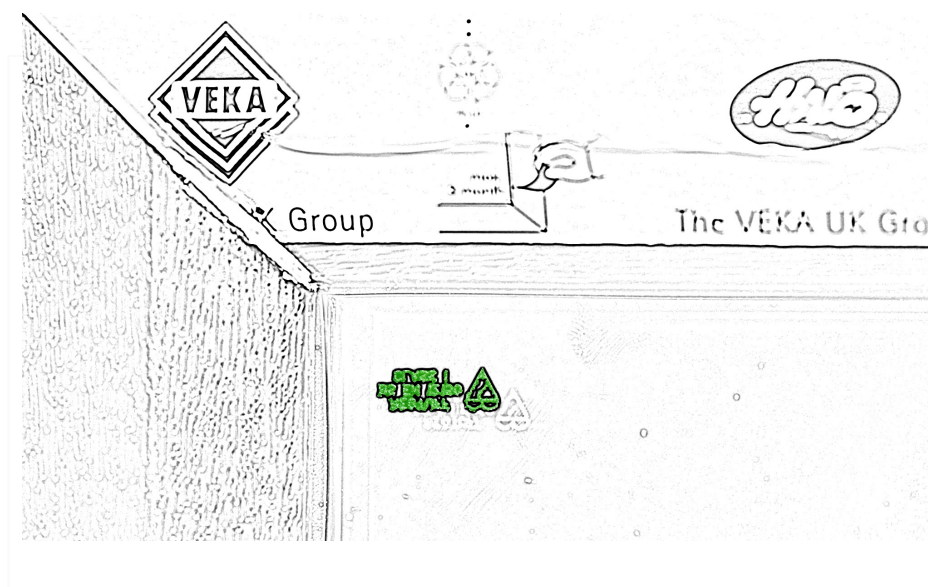

Clip In Packer 109377

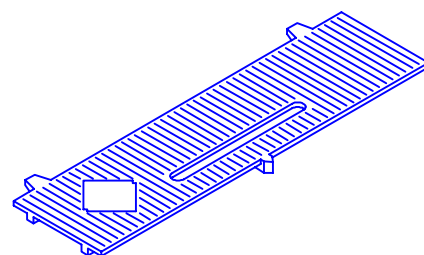

GLAZING PACKERS

Glazing Packers are used to pack the glass unit into the apertures. These packers are to be position adjacent to locking points; additional glazing packers must be used to support the glass on longer lengths.

Always ensure that the packing blocks are wider than the glass unit or panel, e.g. for a unit 28mm wide, use a packer 30mm wide. The Clip in Packers must be placed in the appropriate packing positions prior to placing the glazing unit into the opening.

4

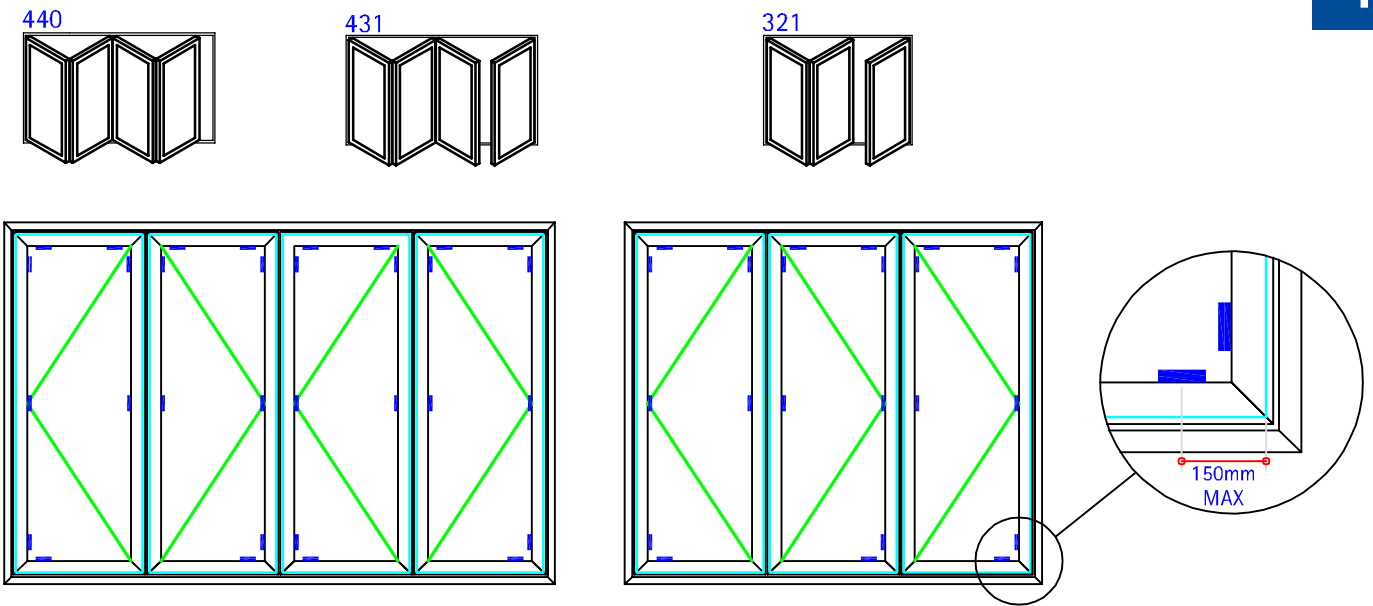

GT Security Glazing Clips are necessary to meet PAS 24 requirements.

Place the appropriate size glass unit into each sash in turn. Toe & healing is necessary. Secure in place with the glazing beads.

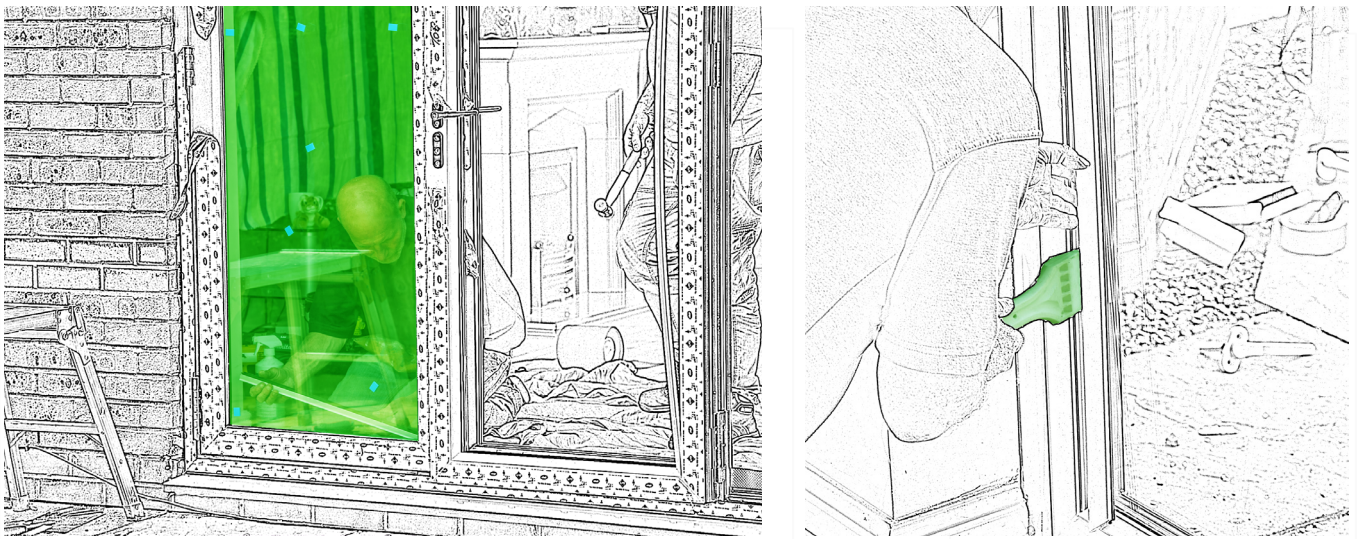

FINAL CHECKS

Debris must be removed from all drainage channels and tracks.

It is recommended that all security grubbs on all hinge types are tightened. It is important that the security grub screw is never loosened after installation.

Whenever a pivot roller is fitted, it is important that the two grub screws that hold the carrier body are fastened tightly so they cannot move. This only applies to the bottom pivot roller.

Check all operations of the door set ensuring locks can be operated easily, rollers operate smoothly and are free from obstructions.

The slave door must be fully locked for the main lock mechanism to operate.

Care must be taken to ensure:

All Bi Fold Doors are fitted squarely.

There is sufficient support at the head such as a lintel.

The head of the frame is secured as firmly as possible.

All glass should be in accordance with BS6262.

4

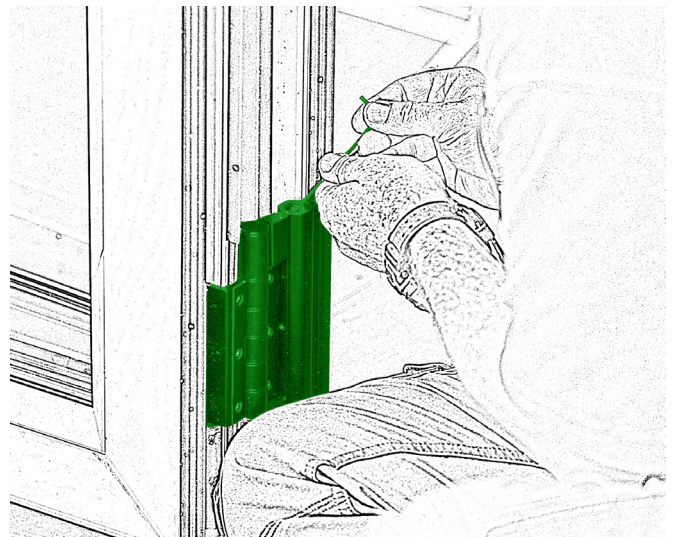



TRIMMING & SEALING

Clean the site before trimming and sealing where necessary.



ADJUSTMENT

-  As a final check during installation, it is recommended that all security grubs on all hinge types are tightened. It is important that the security grub screw is never loosened.
-  Whenever a Pivot Roller is fitted, it is important that the two grub screws that hold the carrier body are fastened tightly so they cannot move. This only applies to the Bottom Pivot Roller.
-  The slave door must be fully locked for the main lock mechanism to operate.

4

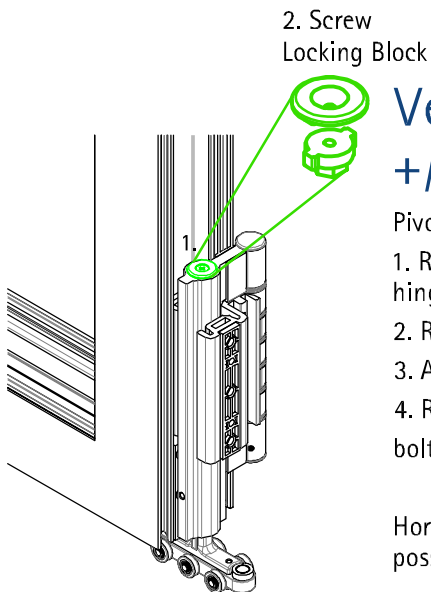

Vertical adjustment +/-2mm

Pivot Rollers

1. Remove the bolt screw from the top of the hinge.
2. Remove the screw locking block.
3. Adjust using a 8mm Allen key.
4. Re-insert screw locking block. Re-fit screw bolt back into top.

Horizontal adjustment of the hinges is not possible.

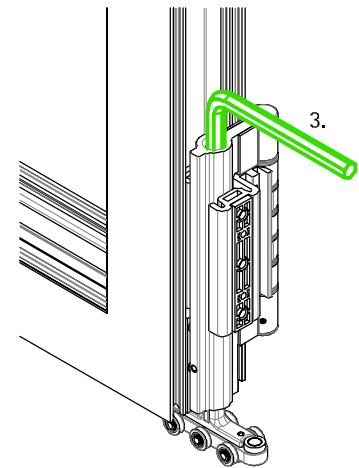

Horizontal adjustment

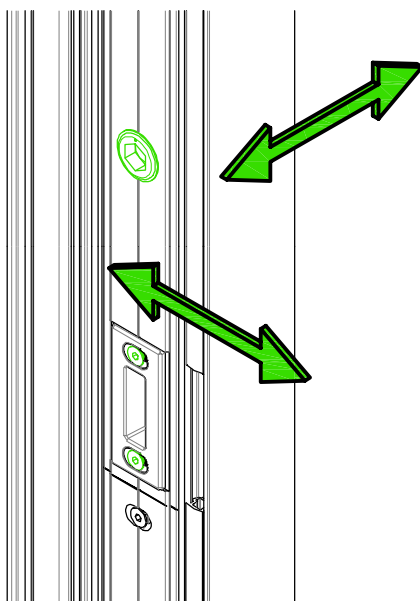

Keep - horizontal + 1 to 4mm: Using a 10mm Allen Key - ¼ turn = 1mm, Full turn = 4mm

Keep - compression +/- 2mm: Using a 2.5mm Allen Key the latch plate can be altered to increase or decrease compression.



HORIZONTAL ADJUSTMENT CONTINUED

Sash to sash horizontal – 1mm to the gap between sashes:

1. Loosen the 6 fixing screws used to attach the adjustment flag of the hinge to the sash.
2. Loosen the adjustment bolts with an Allen Key. Remove the 2mm C-clips.
3. Remove the 1mm narrow strip packer from the back of the hinge plate.
4. Continue loosening the adjustment bolts so that the metal adjustment plate sits flush with rest of the hinge.
5. Carefully tighten back up the 6 fixing screws ensuring you do not strip the profile. Recommended to use a screwdriver rather than a torque gun.

Hinges – sash to frame & sash to sash – horizontal + 1mm to 2mm:

1. Loosen the 6 fixing screws used to attach the adjustment flag of the hinge to the sash.
2. Loosen the adjustment bolts with an Allen Key. Replace the 2mm C-clips with the 1mm C-clips supplied separately. Re-tighten the adjustment bolts using an Allen key.
3. Add either a 1mm or 2mm narrow strip packer supplied separately depending on the amount of adjustment required.
4. Place on top of the current 1mm narrow strip packer.
5. Carefully re-tighten the 6 fixing screws ensuring you do not strip the profile. Recommended to use a screwdriver rather than a torque gun.

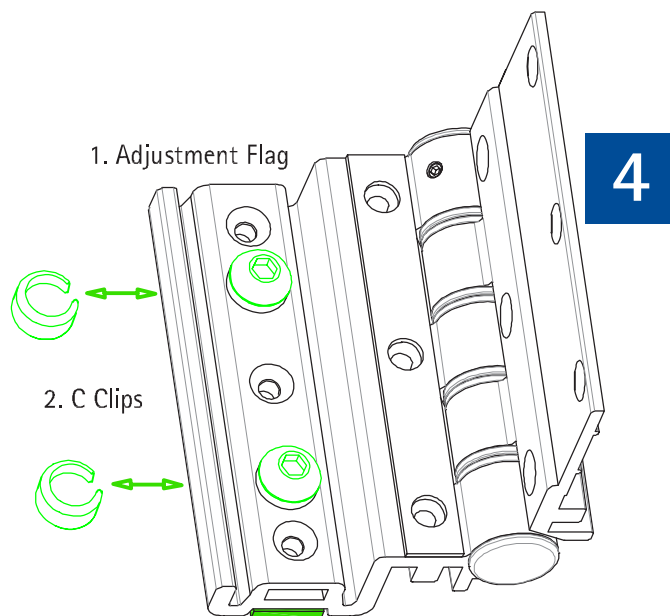

3 & 4. Strip packer behind the metal adjustment plate.

Shootbolt Height Adjustment

1. Slide the spring block and hold to release the shootbolt.
2. Turn the shootbolt to alter the height.
3. Release the spring block ensuring the one of the four slots engage.

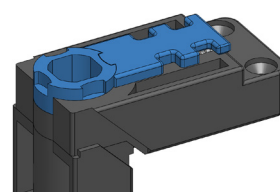
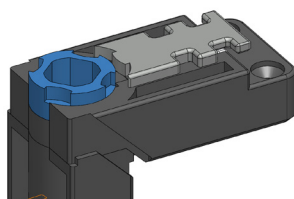
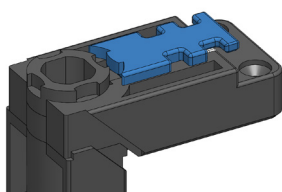
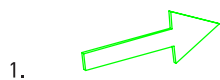

COMPONENTS

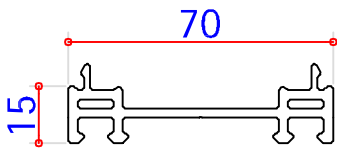

15mm Frame Extension 114028

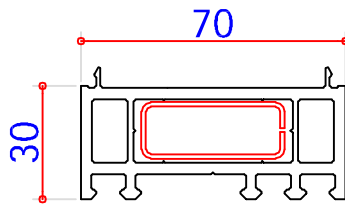

30mm Frame Extension 114014
Steel Box 38 x 15mm 113073

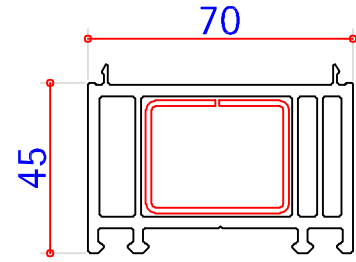

45mm Frame Extension 114202
Steel Box 38 x 30mm 113271

4



Head & Foot Seal 112481
Available in Black or White



Sash Blanking Gasket 112453
Available in Black or White



Traffic Door Gasket 112455
Available Black or White



Jamb Seal 112479
Available in Black or White



Frame & Sash Flipper Seal
112452 Black Only



Fold Gasket (For repair) 112003
Available in Black or White



Edging Profile Gasket
112482 Black Only



Edging Trim 104398
Available Black, White or Foiled



8.5mm Brush Pile
Seal 112365 Grey
Only

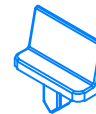

109101 End Cap for
104476

Threshold Cover 104399
Champagne Only

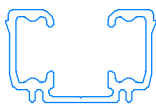

Track 104393
Champagne Only

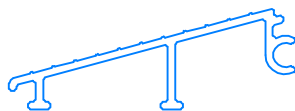

Threshold Ramp 104391
Champagne Only

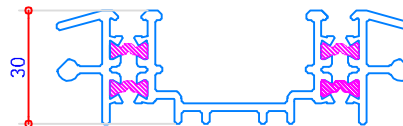

Low Threshold 104392
Champagne Only



Threshold Blanking Piece
104394



Room Divider Threshold 104390
NB. Internal use only Champagne Only

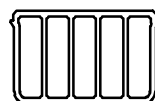

Outer Frame Thermal Insert
105177 available White, Brown and, Caramel



Threshold
Strip 105177
Brown Only



COMPONENTS – CONTINUED



28mm Sculptured
Glazing Bead 107153

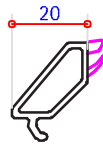

28mm Sculptured
Glazing Bead 107154



32mm Glazing
Bead 107217



36mm Glazing
Bead 107218



40mm Glazing
Bead 107228

4

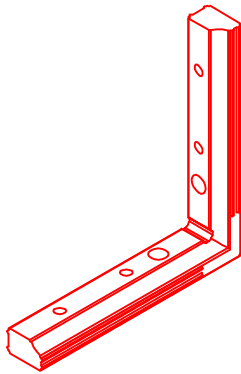

Outer Frame Mechanical Joint Cleat 141429

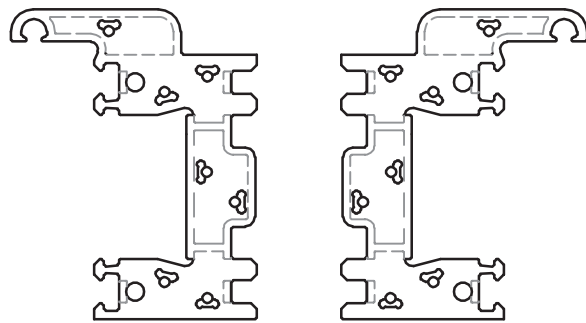

Threshold Mechanical Joint Moulding 109998

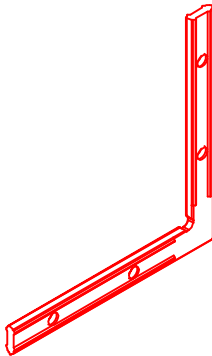

Outer Frame Mechanical Joint Chevron 141431

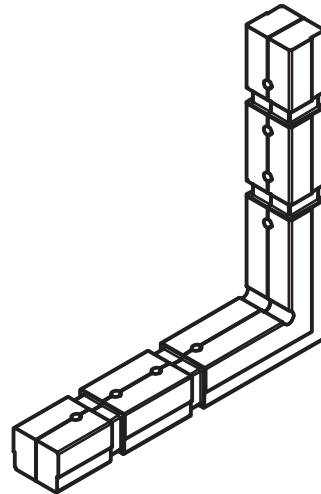

Outer Frame Mechanical Joint Moulded Cleat 141430

DOOR RESTRICTOR

140310 Imagine Opening Restrictor

For use on Imagine Bi-Fold Traffic Opener or Flush Door sashes only.

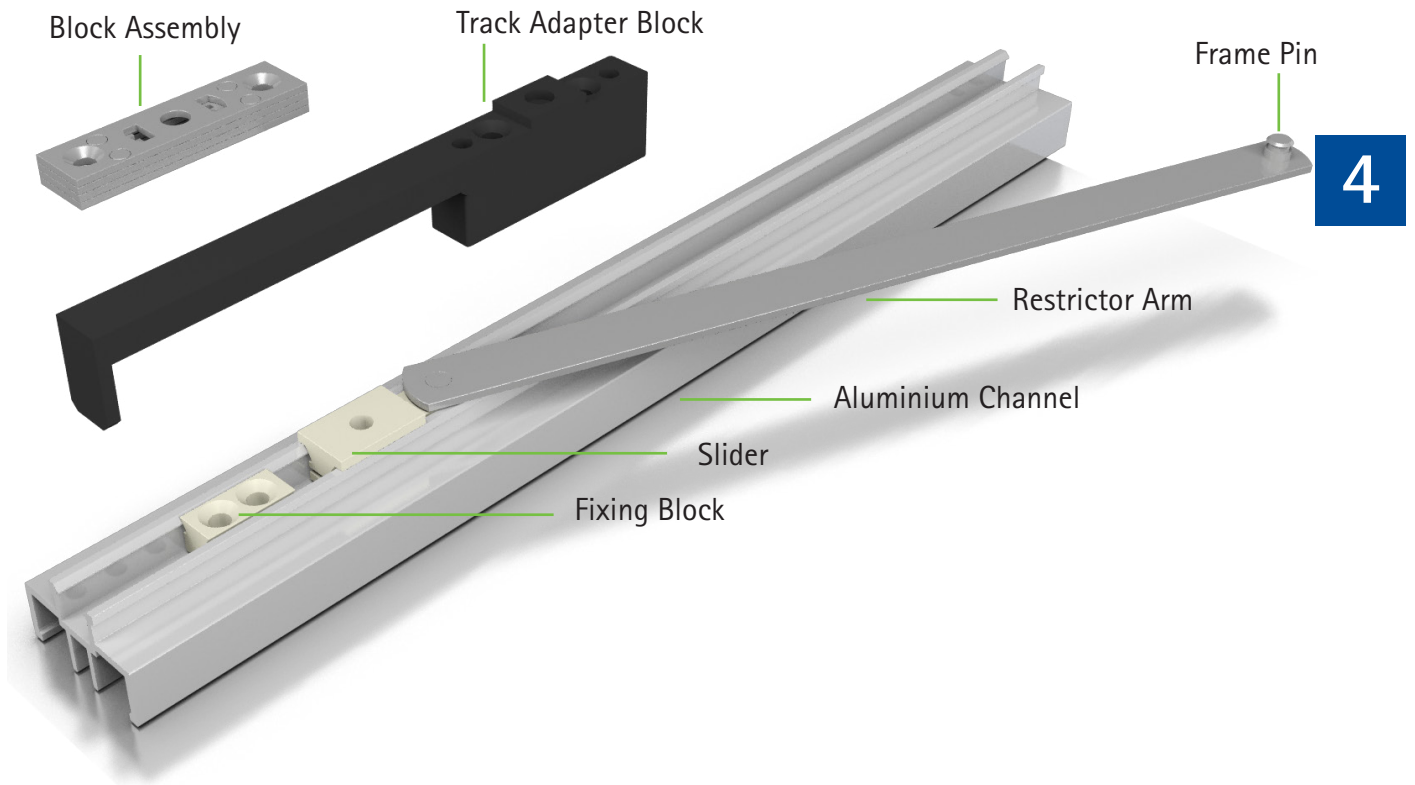

Adjustment of the angle the sash is allowed to open can be achieved by altering the position of the fixing block.

Attach the aluminium channel and arm to the head of the traffic door sash using 38mm drill point screws. The aluminium channel should be positioned up against the corner block moulding.

The speed or ease of the restrictor can be altered using the brass grub screw in the slider.



DOOR RESTRICTOR – CONTINUED

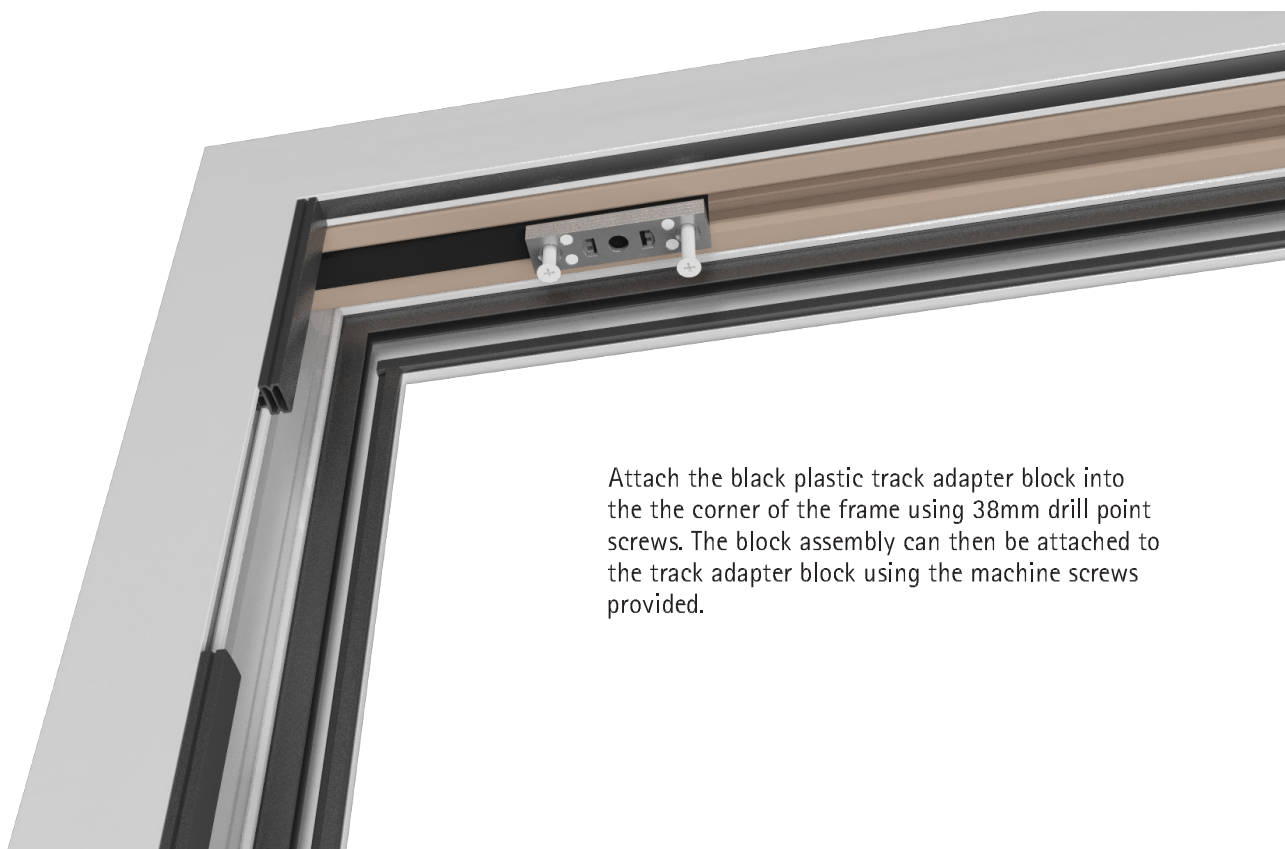

4

Attach the black plastic track adapter block into the the corner of the frame using 38mm drill point screws. The block assembly can then be attached to the track adapter block using the machine screws provided.



Once the sash has been hung into the outer frame the frame pin can then be pressed into the spring clip inside the block assembly.



OPTIONAL SPARES & MAINTENANCE

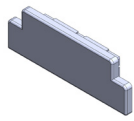

Keep End Cap Black 140001754610

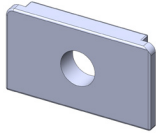

Lock End Cap Black 140001763810



Latch Striker Plate Silver 140001838234



Hinge End Cap White 140001751201
 Black 140001751210



Screw Cover White 140001774201
 Black 140001774210
 Chrome 140001774234
 Gold 140001774237

4

Maintenance

- To prevent damage of the adjacent door sash remove the key from the cylinder immediately after locking or unlocking.
- The stainless steel rollers and bearings require no lubrication.
- Top and bottom tracks should be kept free of debris.
- Locking mechanisms may require a small amount of light machine oil around once a year.
- PVC parts should be cleaned regularly with soapy water.
- Periodically clean the glass with warm soapy water (washing up liquid). Dry with a lint free cloth and remove any excess water.
- **Do not** use any type of harsh cleaning agents such as white spirit, WD40, automotive dashboard wipes, acids, brick wash solutions or alkalis.



AMENDMENTS

Page	Previous Issue	New Issue	Details	Initial

5



This document is uncontrolled once printed.

The VEKA UK Group
Farrington Road
Rossendale Road Industrial Estate
Burnley
Lancashire
BB11 5DA

T: 01282 716611
E: technical@veka.com
W: www.vekauk.com



FOR NOW
FOR THE FUTURE
FOR LIFE